



## 3.5 INCH IMAGE SHIFT (WOBBLE) INFORMATION

Questar Corporation has manufactured extraordinarily fine instruments for 50 years and has produced approximately 16 thousand units which are all are closely related in construction, assembly process and internal mechanism. As with all products there have been alterations, material changes and minor design alterations but the overall original unit concept is the same. The following is a brief history of one of the internal mechanisms, which seems to create the most concerns and questions about the Questar 3.5.

### **Image shift:**

#### **The apparent image displacement in the eyepiece when changing focus of the instrument.**

It is Questar's policy to give the user a general rule of thumb as a guideline for its assembly process and technique. If a customer had concerns or complaints we evaluate the particular unit in question and adjust it to the best of our ability. **Image shift is inherent in all Questar 3.5 units** and varies in the degree of shift. No matter what model or age, the image shift will be there. It will vary with eyepiece used, temperature and angle of the tube in declination. It will vary in direction and speed. Questar takes painstaking efforts to reduce the image shift based on our exacting specification in every unit produced. Each unit, however, has its own individual characteristics, which vary but must meet our shift specification. Questar has always been concerned about its products and strives to produce the finest telescope available in the world.

#### **Questar's image shift specification:**

- The image may not shift more than 1 crosshair line in any direction on the image shift 16mm testing eyepiece. Angular shift of 30 arc seconds maximum. (one Jupiter diameter)
- The unit will be tested and judged using the above criteria at three distances, 20 feet, 150 feet and infinity using the infinity collimator.
- The unit will be tested and judged using the above criteria at two tube angles, 18° and 30°.
- The unit will be evaluated for type of shift. Such as fast jump, slow jump, focus rod jitter, cork screw.
- The unit will be tested at two temperature conditions, Indoors and outdoors. Indoors is generally 70° (F). Outdoors is seasonal dependent. Ranges from 25° to 95° (F)

#### **Checking calibration of 16mm testing eyepiece:**

The 16mm testing eyepiece is a Questar Brandon type with a fixed graduated reticle at the focal point of the eyepiece. It is 80 x 80 X-Y chrome on glass type. Calibration testing will use sidereal tracking time as a constant to determine angular separation of cross hatches.

Test information: Time = 80 seconds, lines traveled = 40 lines, sidereal time = 23-56-4.091/360° (1 sec = .004178°)

$$80 \times .004178 = .33424^\circ / 40 \text{ lines} = .008356^\circ \text{ per line}$$

$$.008356 \times 3600 = 30.08 \text{ arc seconds / line}$$

### What causes image shift:

Image shift is the effect of small amounts of internal play between focusing mechanical parts. The Questar 3.5 has three major parts, the mirror thimble, the main tube and the focus rod. The drawing that follows is a simplified depiction of these components. **Any play between the thimble and the main tube will result in image shift when focusing. The degree of play will affect the amount of shift.** A quantified number is actually hard to determine in regard to the play involved between parts. As stated earlier this image shift should not exceed 30 seconds of arc. Care should be taken not to confuse image shift with *focus rod induced shift*. The focus rod is sensitive to vibration and deflection from the user. If you were to grasp the rod and torque it in any direction, a resulting shift would occur. Image shift is best seen when the focus rod is grasped lightly and a slowly rolled between the thumb and index finger with an in/out motion of the focus rod. When the rod changes direction the image shift will be visible. Again the direction, degree and harshness of the shift will vary but should be less than 30 arc seconds. Questar strives to hold to and generally will exceed this specification.

Image shift may also be caused by temperature changes, vibration and transportation, which will increase or decrease the amount of shift. Image shift which exceeds our specification does require returning the instrument to the factory for adjustment and also is thoroughly, checked and adjusted during a service if it is possible. Not all Questar 3.5 units can be adjusted. Early Questars have no internal mechanisms which allow for any adjustment. If you have one of these units (50's or 60's vintage) we will only be able to check image shift. Repair will require replacement of internal parts (wide-field conversion or replace main tube and thimble).

### Internal Components History

- 1950 The 1950 units were manufactured much the same way as current units. They have a similar focus assembly with a main tube and thimble. The major difference is the diameter of mating parts and the inability to adjust fit (Narrow-Field). The main tube and thimble tubes were close fitting and were not adjustable. The thimble had a slightly longer footing. This coupled with a full-length friction metal to metal contact made these units feel stiffer to focus. This stiffer feel also makes it harder to detect image shift, which in some instances makes it seem to have less image shift. The focus arrangements with rod, spring and mirror nut are the same as a current model.
- 1960 Sometime in the 60's (early) Questar started using a different main tube and thimble arrangement known as Wide Field. This was the predecessor to today's design. It involved enlarging the main tube diameter and modifying the thimble design to allow for image shift adjustment via (8) eight friction pads. This was a two fold design change one of which was to allow adjustment for image shift and, secondly to allow more light throughput to the image plane for photography. The reduced friction from the new design changed the feel of the focus from stiff to buttery smooth. The main tube of this era may not have had a Teflon coating. This was also when Questar started using aluminum tubes instead of Synthane. Switching over to the aluminum should have been completed around 1969.
- 1970 Improvements and prototype designs. During this period Questar tried many different combinations of slide coatings, spring arrangements and tensions, thimble pads and a special integrated ball bearing and pre-load design. The current design has not changed since the 70's. Currently the main tube is centerless ground and Teflon coated and baked to a hard finish. The thimble is precision machined and has 8 adjustable inline pads. These pads are hand fitted to each individual main tube and adjusted until the image shift is within our specified tolerance.

## BASIC INTERNAL LAYOUT

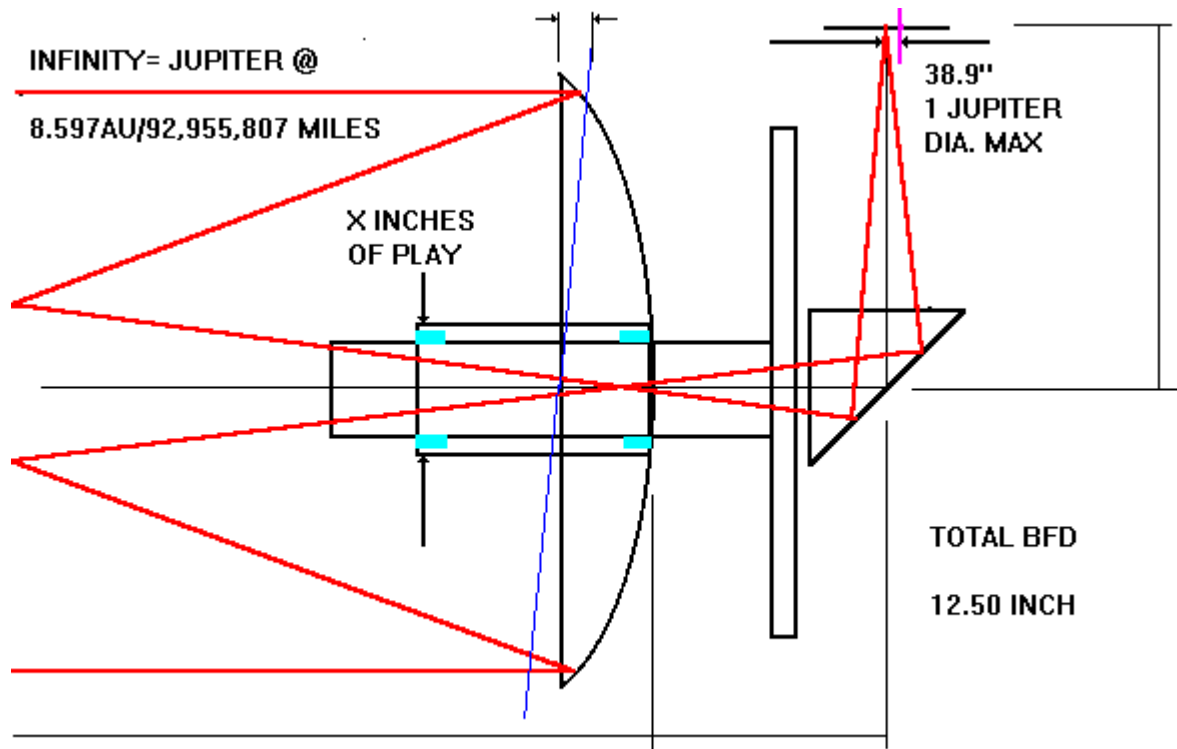

## 1950/1960 MAIN TUBE AND THIMBLE INFORMATION

NARROW FIELD UNIT

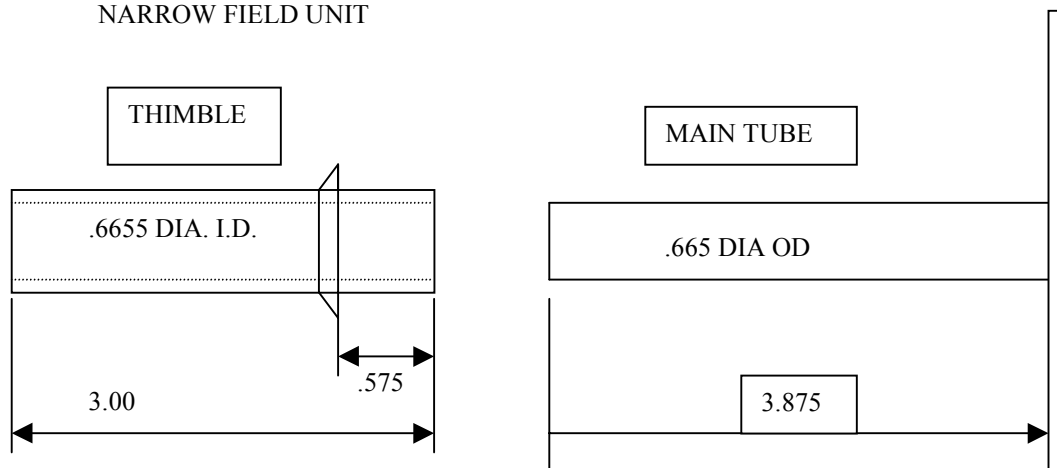

THESE UNITS HAVE THE SAME FOCUS ROD THREAD AND LOCATION, OFF AXIS AS CURRENT UNITS. THIS LOCATION IS 15/16 DOWN FROM OPTICAL AXIS AND .500 OVER. A CONICAL SPRING WAS LOCATED ON AXIS IN MOST UNITS AROUND THE MAIN TUBE.

# 1960/2000 MAIN TUBE AND THIMBLE INFORMATION

WIDE FIELD UNIT

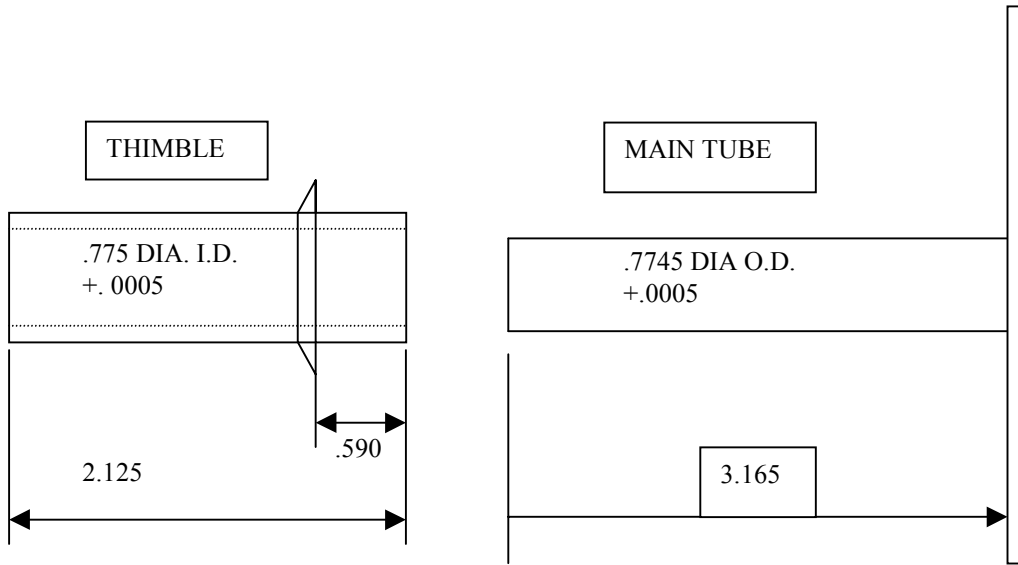

4 ADJUSTABLE PADS  
INLINE WITH ROD

PADS ARE .09  
WIDE AND .09  
LONG IN FROM  
ENDS OF  
THIMBLE

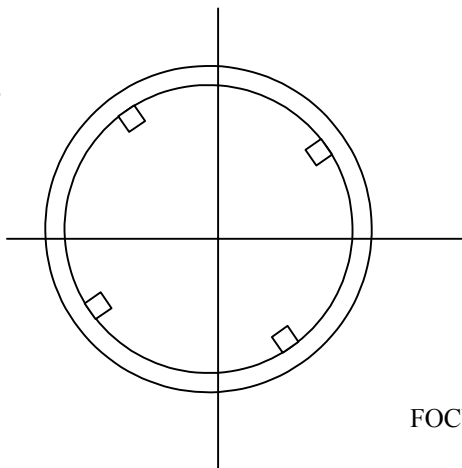

FOCUS ROD

